



Extending Open Source PBX For Scalable Media Gateways

**Presented by: Nenad Corbic, B.Eng
Chief Software Engineer
Software Manager
Sangoma Technologies**

Limitations of Current Soft PBX Architecture

- **Monolithic/Single Server Architecture.**
- **TDM Bottleneck (Zaptel/TDM Hardware)**
- **Software Echo Cancellation & DTMF & D-Chan HDLC**
- **Software Codec (g729)**
- **Kernel / User Space Context Penalty**
- **TDM Clustering Solutions limited and hard to configure**
- **Customer need for 16 x E1 \approx 500 calls or greater !**

Current Asterisk Open Source PBX Model

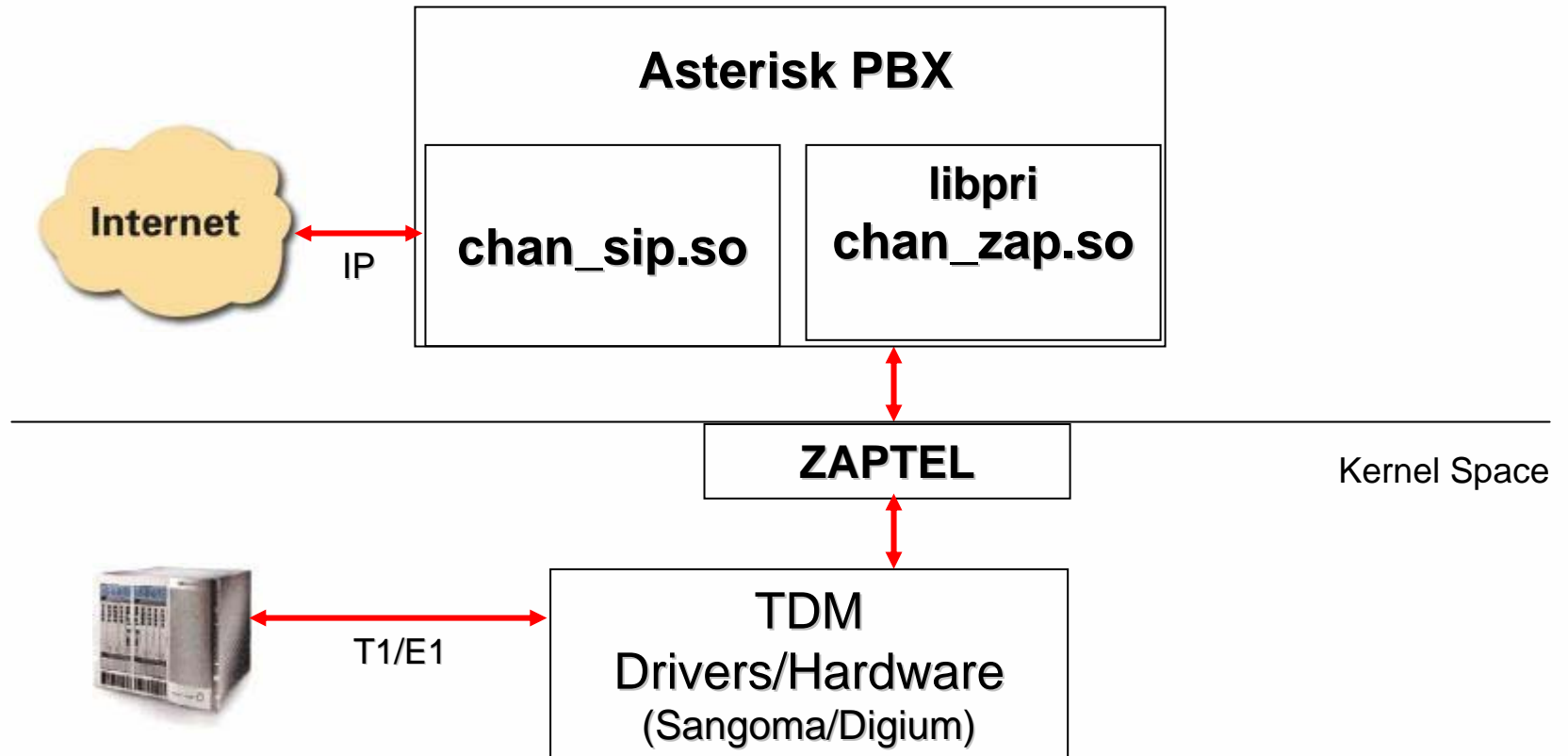

Hardware Interrupt Penalty: SW EC & DTMF

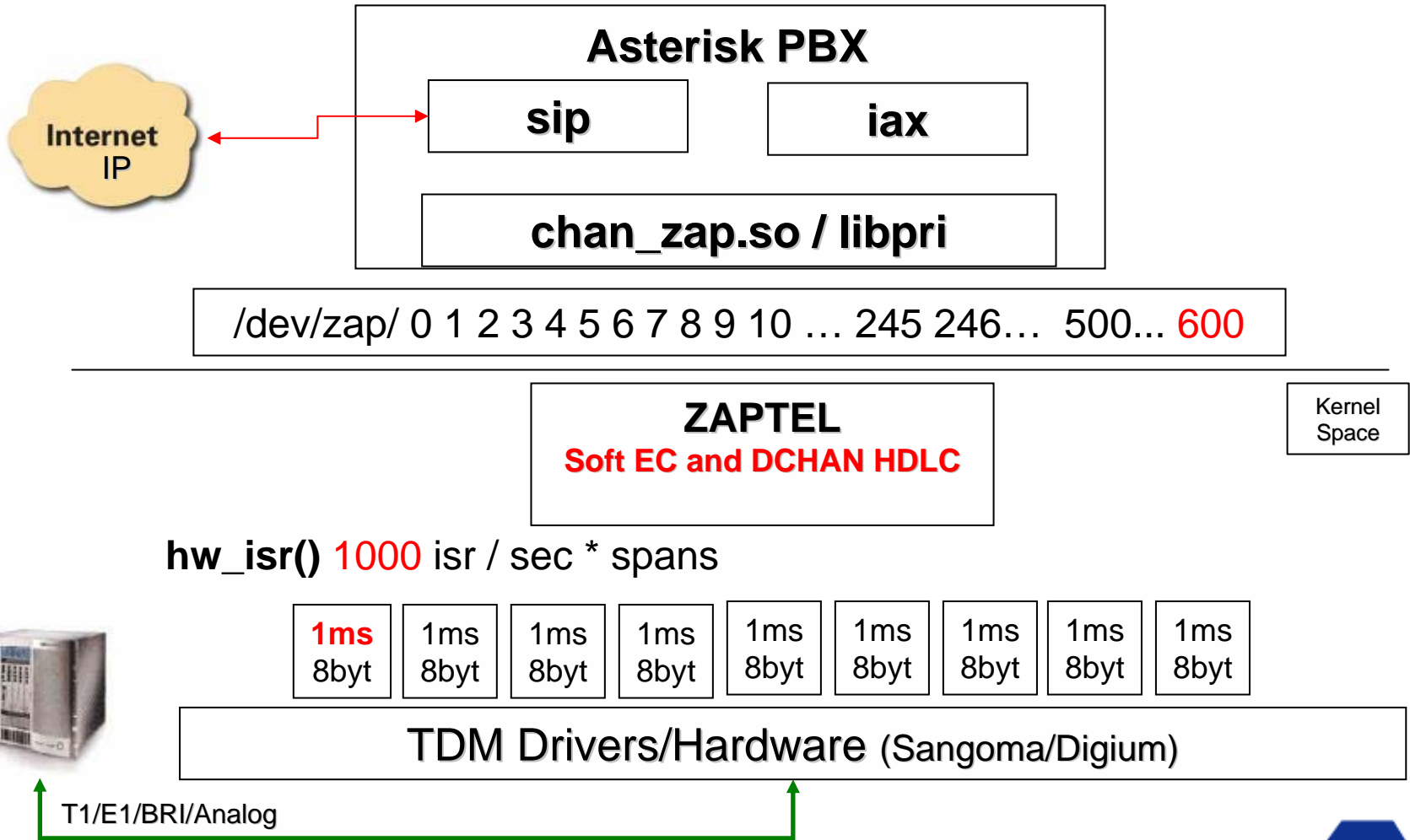

HW Optimizations: EC & DTMF & DCHAN HDLC

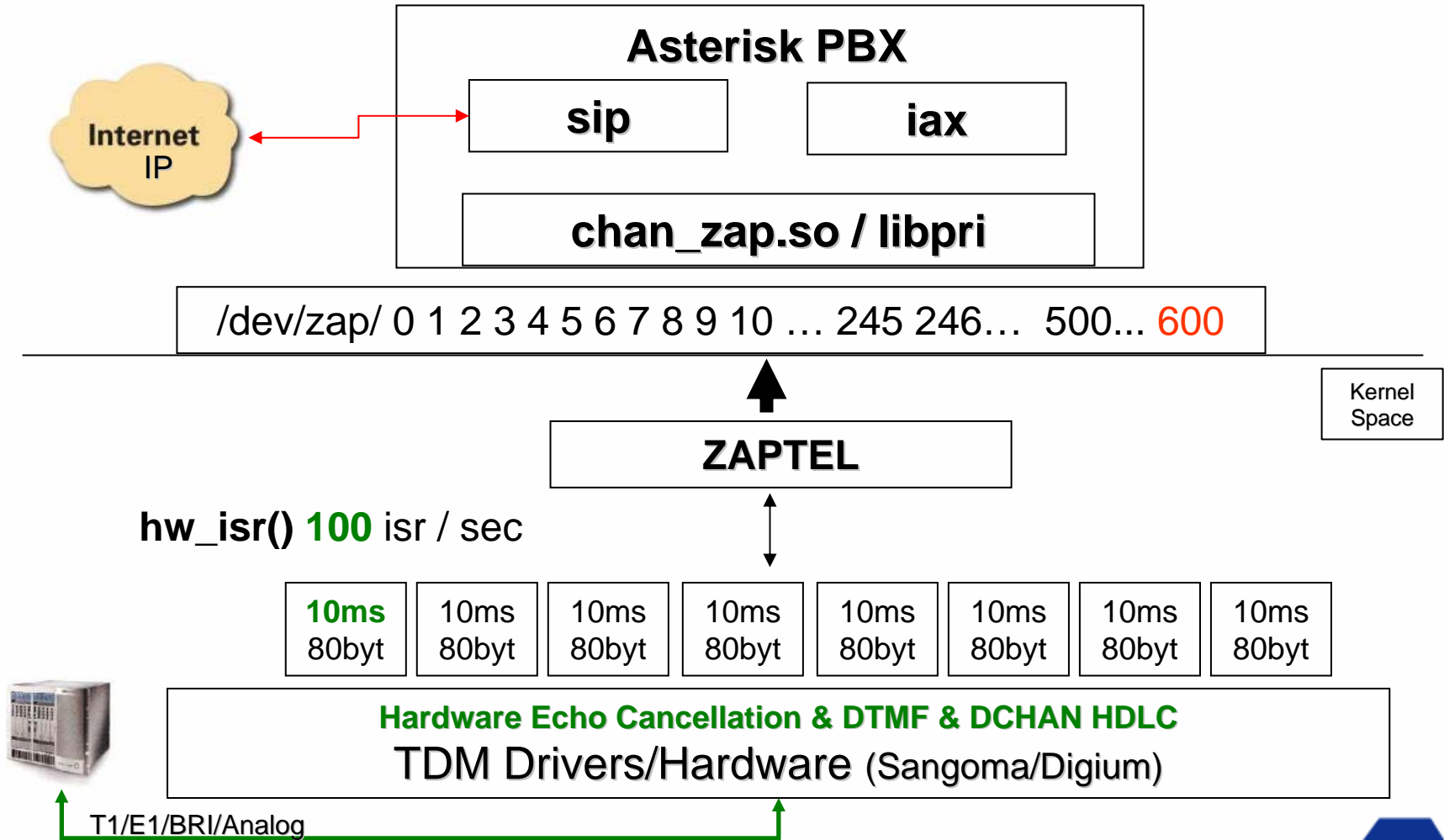

Kernel Context Penalty

- Greater the number of kernel devices, the greater the context penalty.
- System doesn't scale over 500 individual channels.
- Where each channel receives its own kernel device.
- Solution is to move to a **per span** kernel device.
- This way all channels inside a span are read in a same kernel context.
- Stage two solution is to memory map user space into kernel space and have zero copy transfers from kernel to user space.

Create kernel device per Span

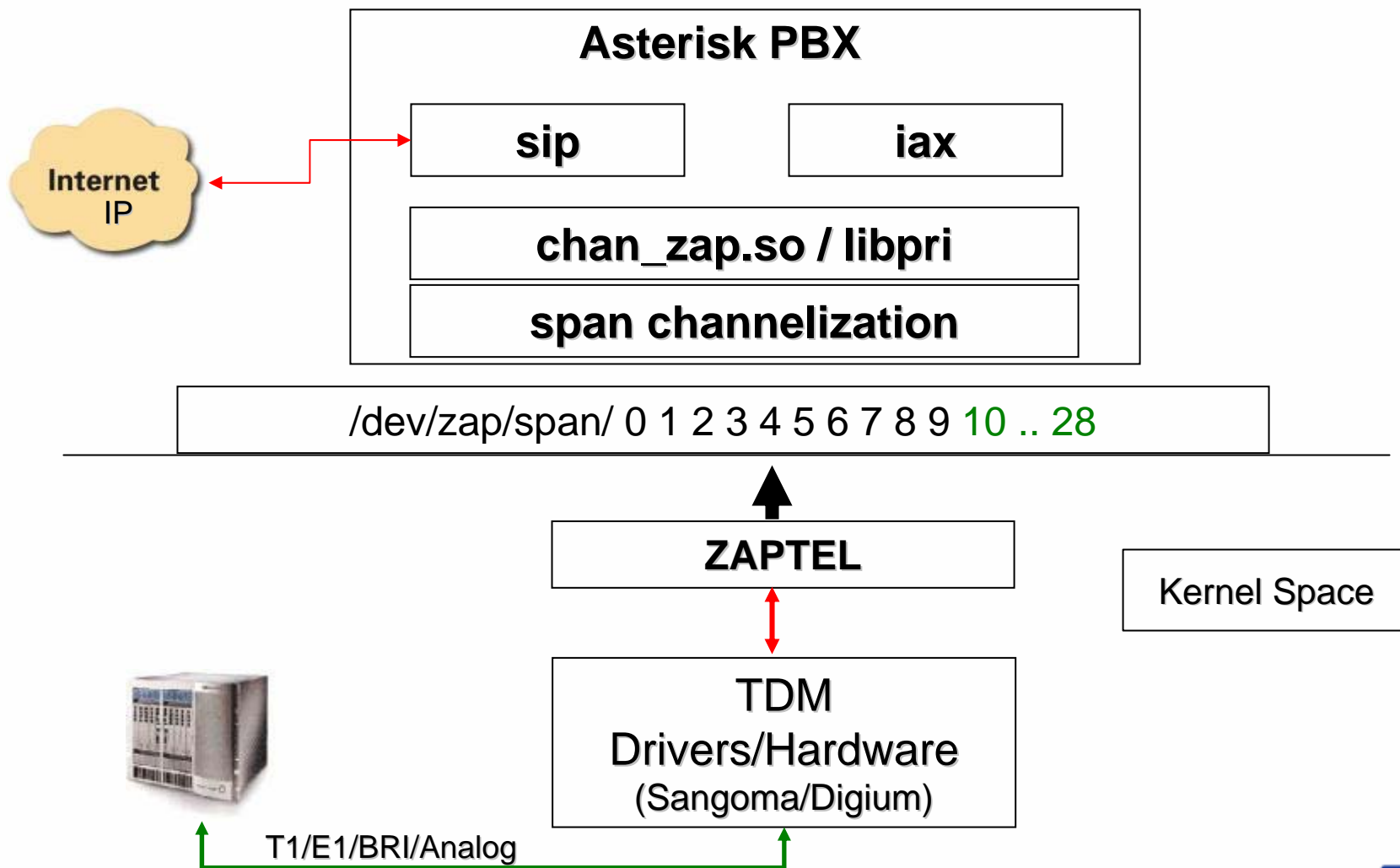

The Distributed TDM Architecture: **Woomera**

- **Started as a response to a business need**
- **Providing a carrier-grade SS7 interface to Asterisk and others.**
- **A need to support 16 + E1 lines.**
- **Woomera Protocol: TCP Control Socket + UDP Media Socket (Woomera offers leverage)**
- **Design a Generic Channel Driver using Woomera for Asterisk.**

Woomera Asterisk PBX Model

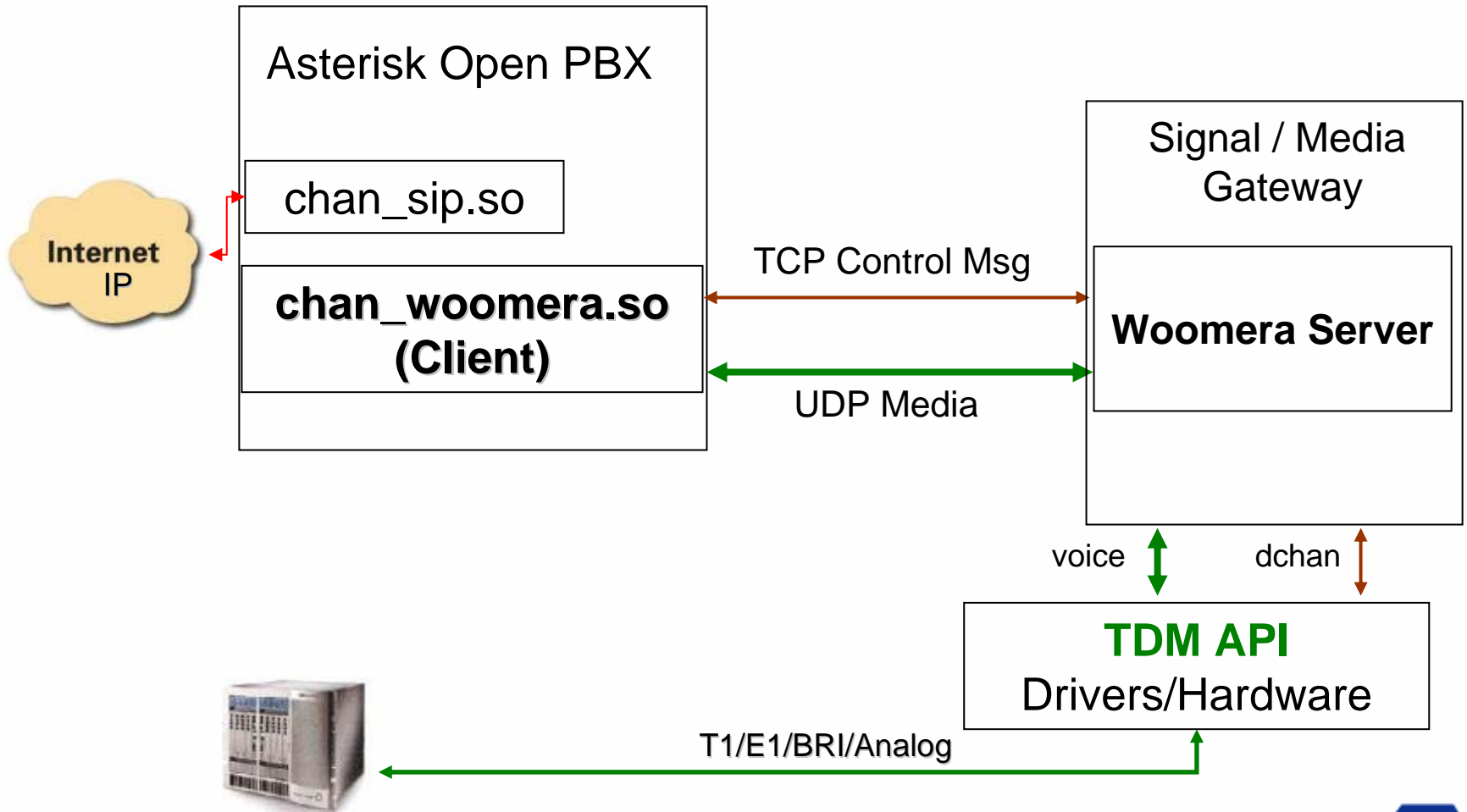

Woomera Control Protocol

- **TEXT based Call Control Messages (carried over TCP)**
- **HELLO, CALL, HANGUP, LISTEN, ACCEPT, ANSWER, DTMF, BYE/QUIT**
- **Each command is transmitted in ASCII text format**

EVENT HELLO

Version: 1.0

**Supported-Protocols:
h323,sip,iax.ss7,pri,bri**

CALL

bri:g1/9054741990

Raw-Audio: 192.168.1.1:9000

Request-Audio: raw

ACCEPT

Unique-Call-Id: id1

EVENT MEDIA

Unique-Call-Id: id1

Raw-Audio:192.168.1.1:9000

- **UDP based: Media (ulaw,alaw,PMC-16...)**
- **RFC in progress...**

Object Oriented Telephony Design

- **Each piece is well defined**
- **Reuse of debugged modules**
- **Reduced Bugs**
- **Increased Stability**
- **Increased Asterisk Stability**

Distributed Woomera TDM Architecture

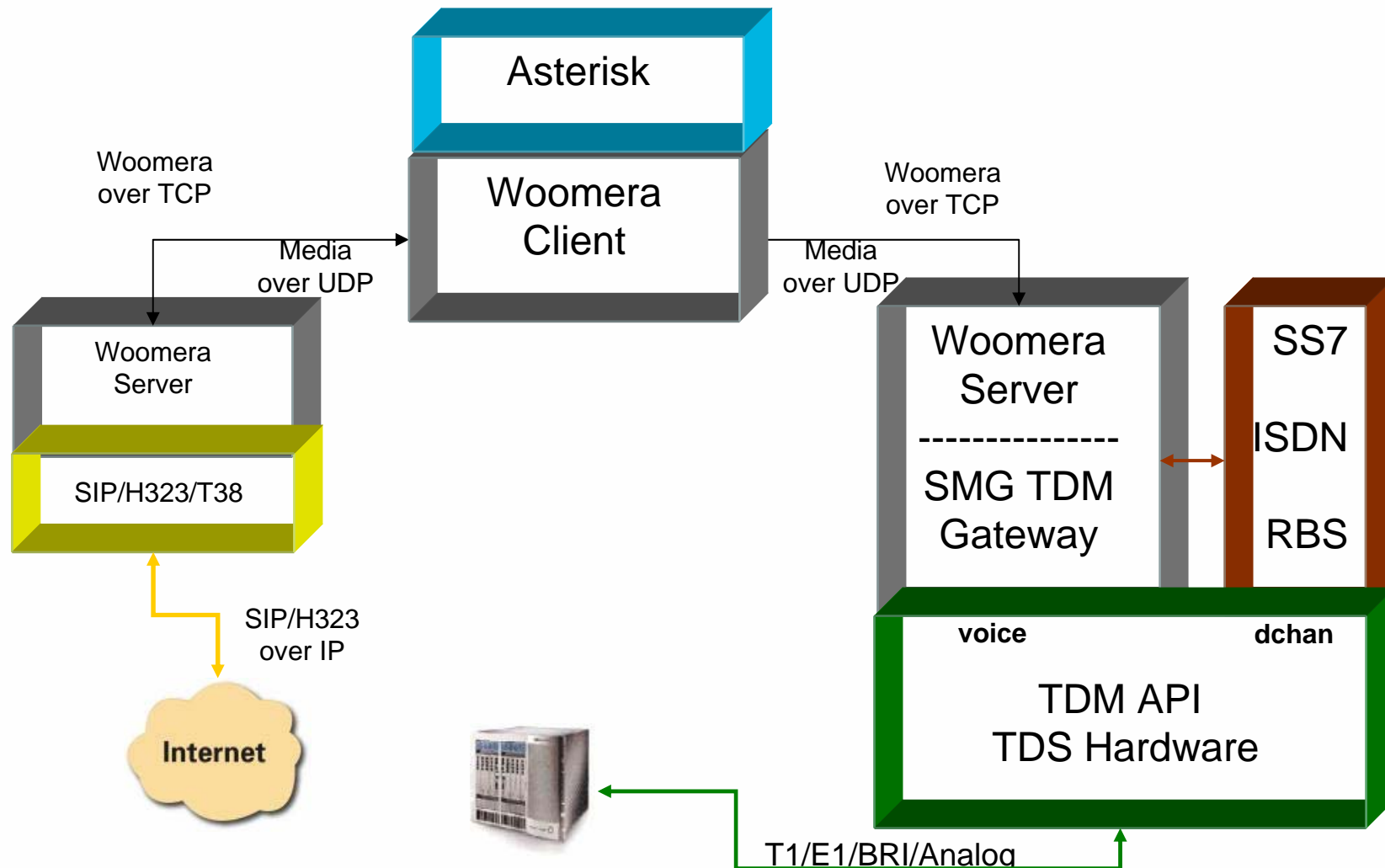

Distributed Clustering Woomera TDM Architecture

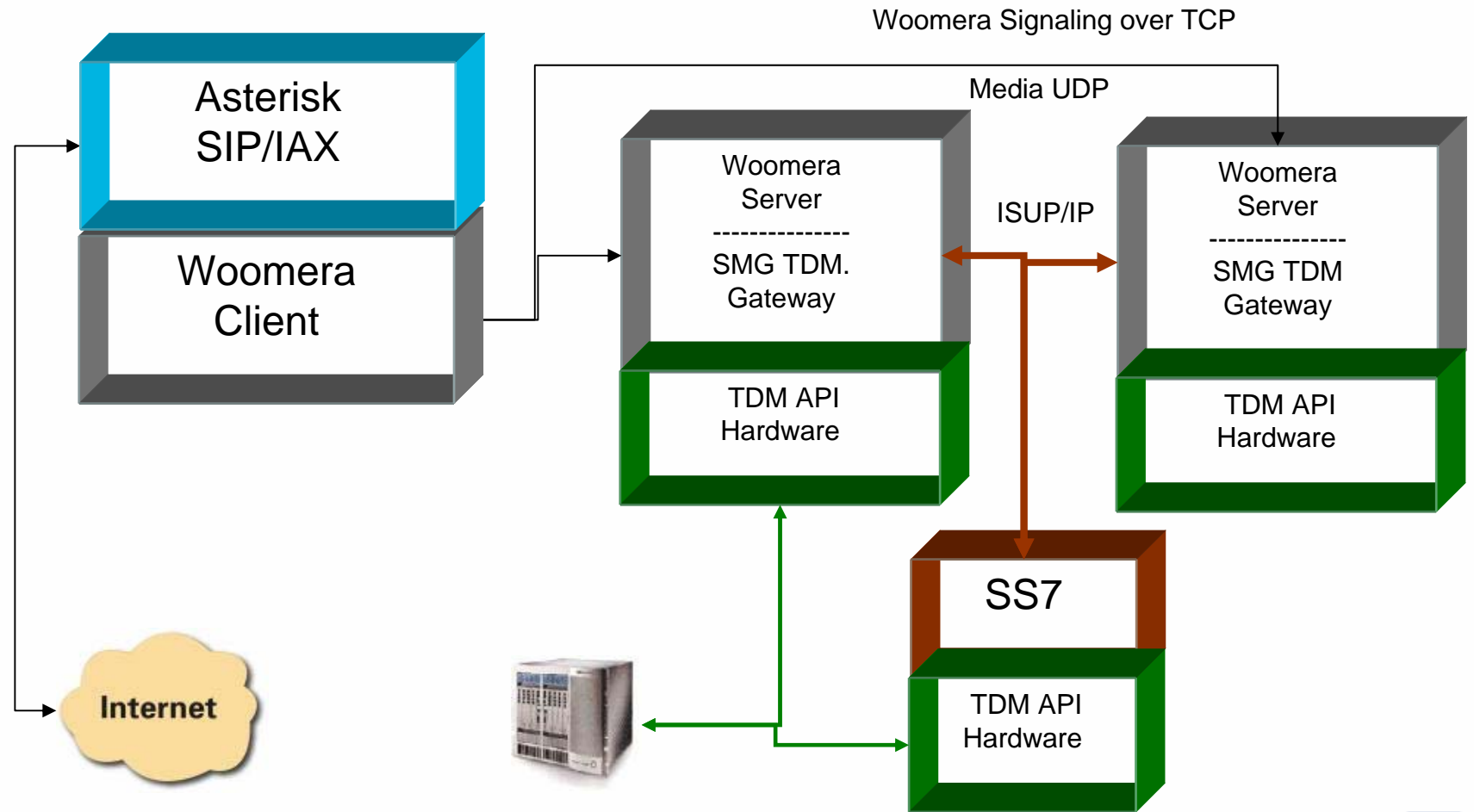

Distributed Woomera TDM Architecture

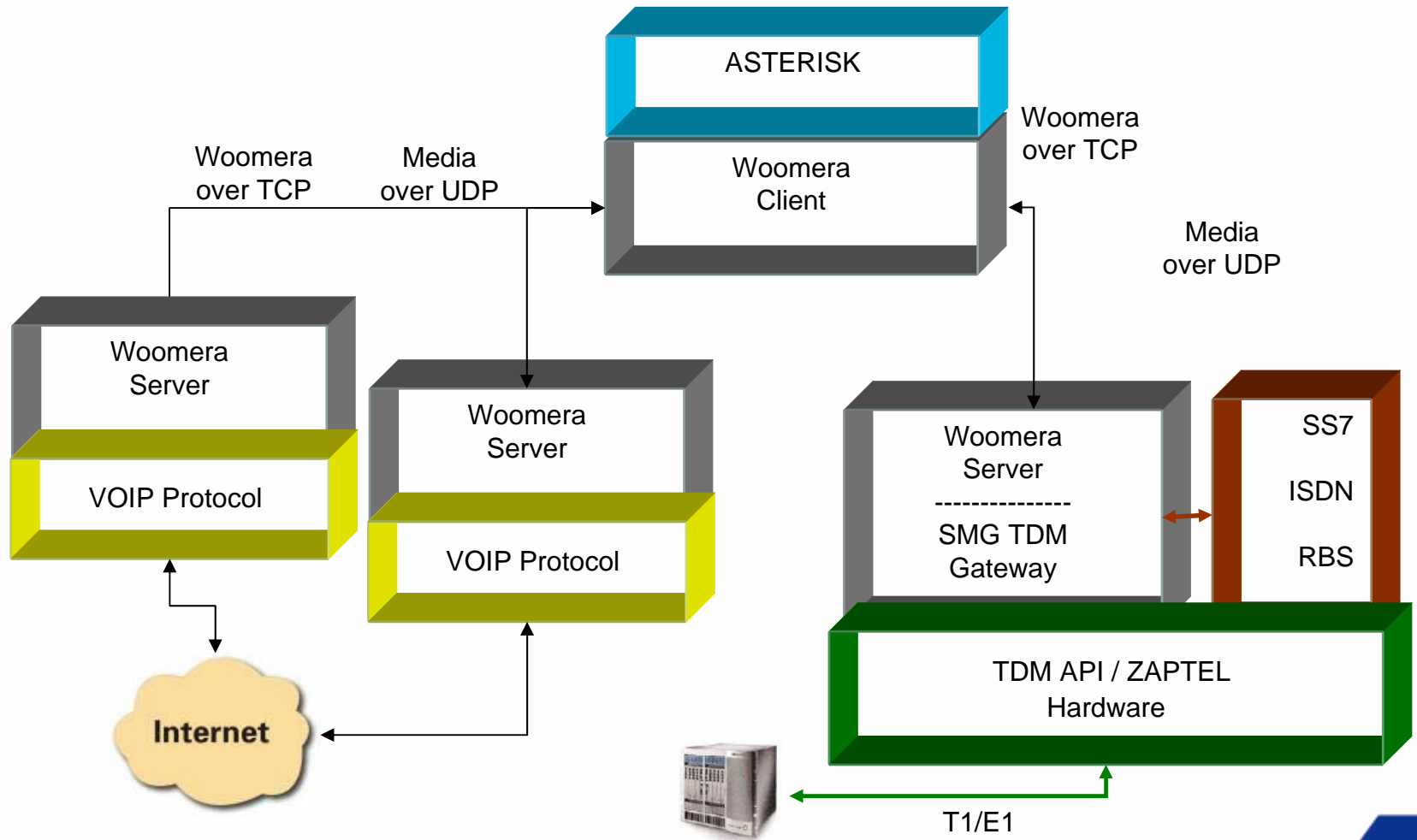

Auto Asterisk Load Balancing Scaling

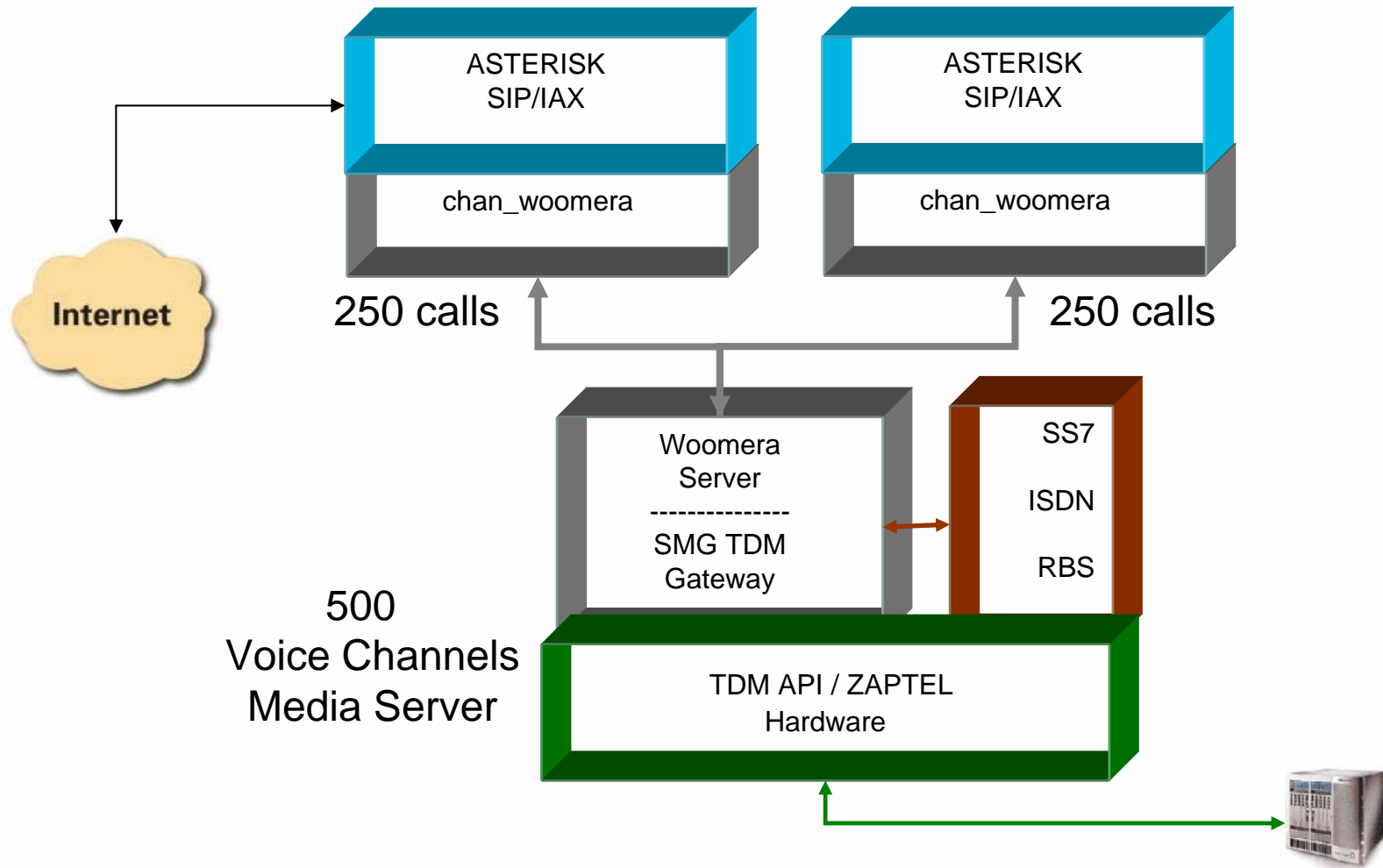

Distributed Clustered Scaled Asterisk & SS7

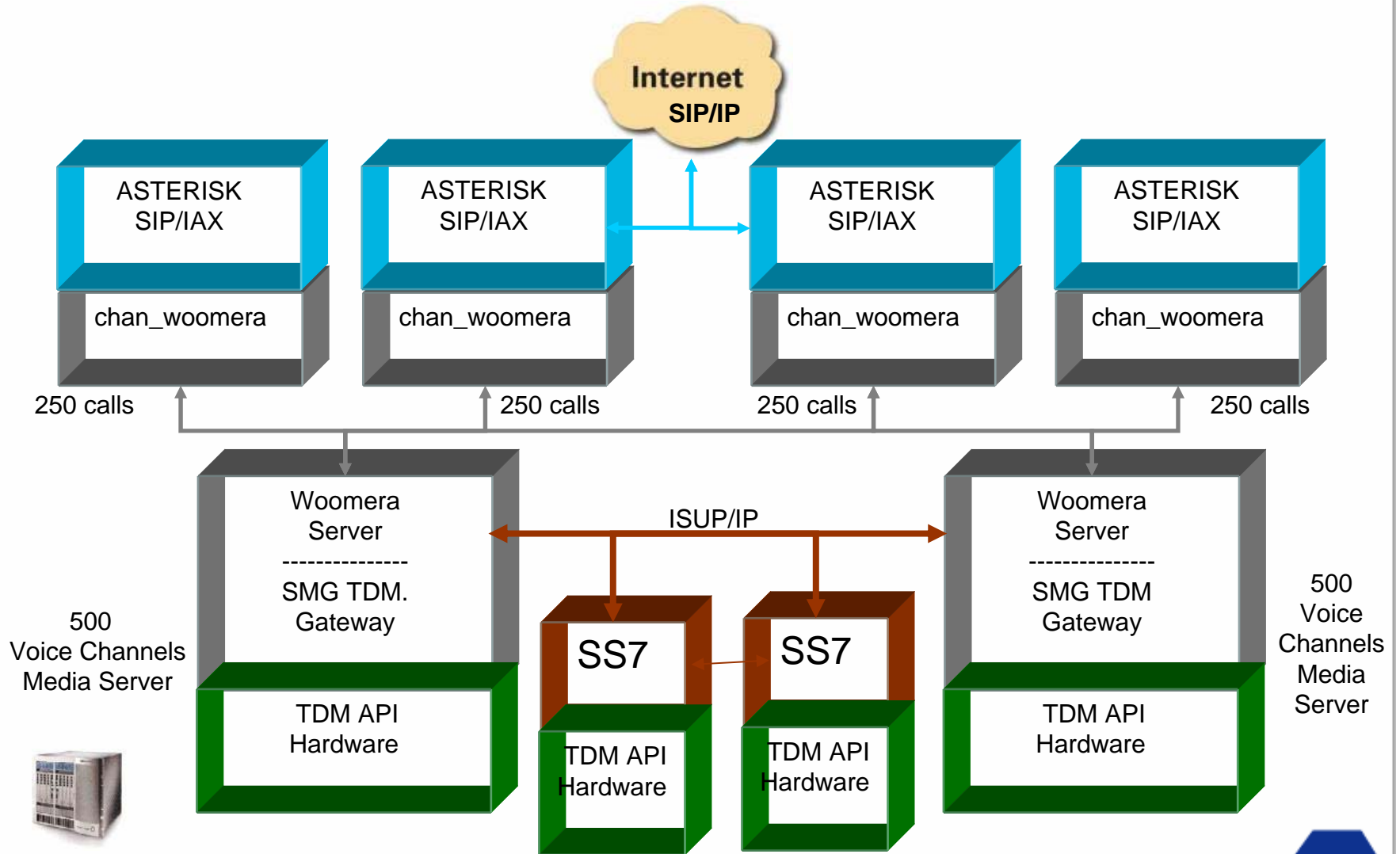

Sangoma Wanpipe RTP TAP : Voice Recording

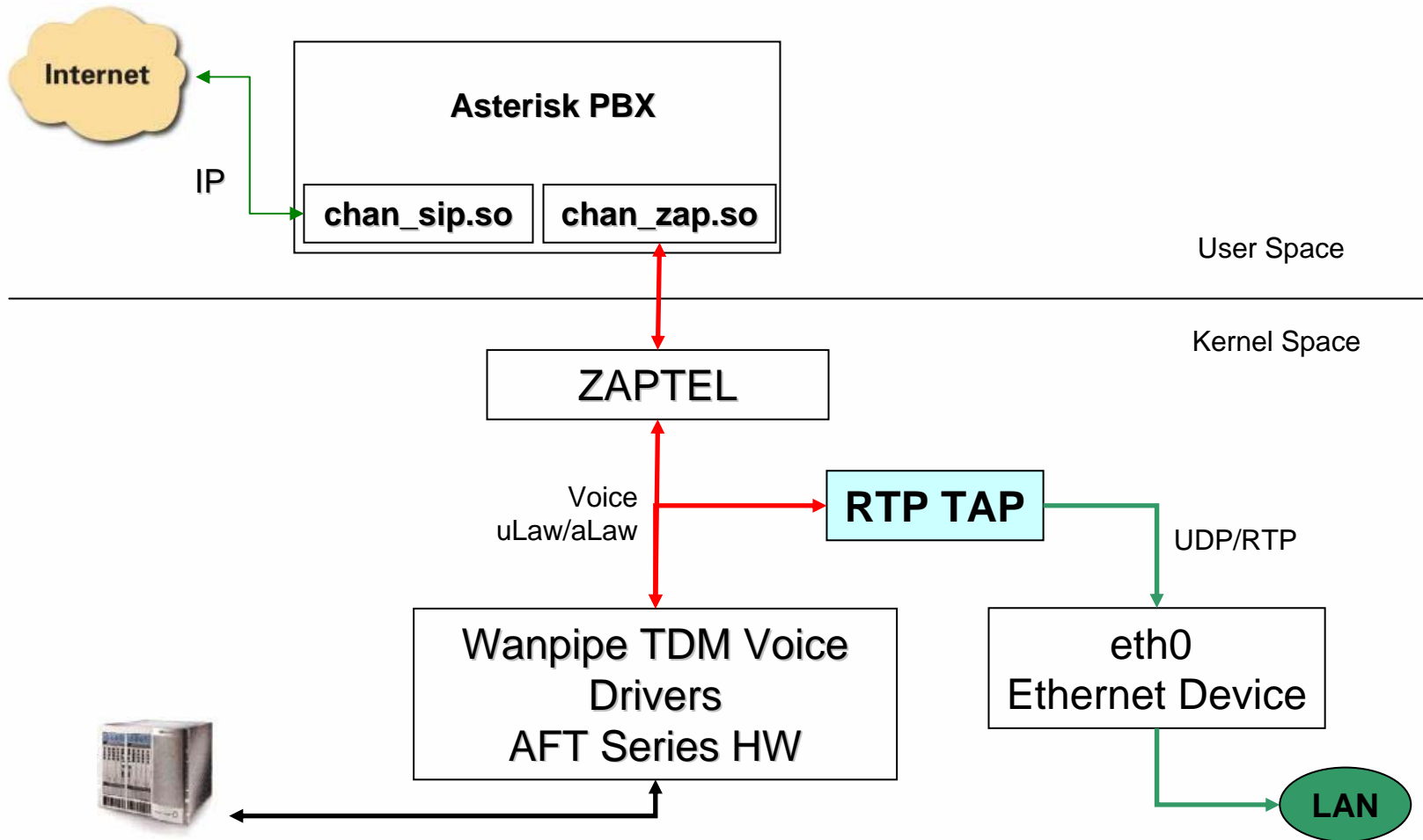

Distributed Performance

- **Asterisk can handle 500+ SIP-SIP calls**
- **Woomera channels are lighter than SIP/RTP**
- **Asterisk should be able to handle 500+ distributed Woomera TDM to TDM or SIP to TDM calls.**

Future of Open Source PBX/Gateways

- Demand is growing!
- Need for 16 + E1 media gateways.
- Distributed model works
- Asterisk is the answer
- Asterisk Telco Grade?



Thank You!

Questions and Comments?